

IS IT POSSIBLE

IS it possible for a note to be in three separate securities, yes.

IS it possible that the servicer of one of these securities is the servicer for the other two, yes.

IS it possible that one of the securities is identified as holder/owner who wants to foreclose, yes.

IS it possible that the other two securities have no idea of a foreclosure action but just notice from the servicer actions are pending, yes.

IS it possible that the other two securities have no idea of a foreclosure action but just notice from the servicer actions are pending, yes.

IS it possible that it IS easier to tell all three securities here is what you get from a foreclosure sale less fees, yes.

IS it possible that the foreclosure is to cover up that the note was used in three securities, very probable?

Can it be proved, yes.

**Ask Fannie Mae
Principal Only Split, Interest Only Split
MEGA's-(Non Traunch Splits of Certificate)**

Investor

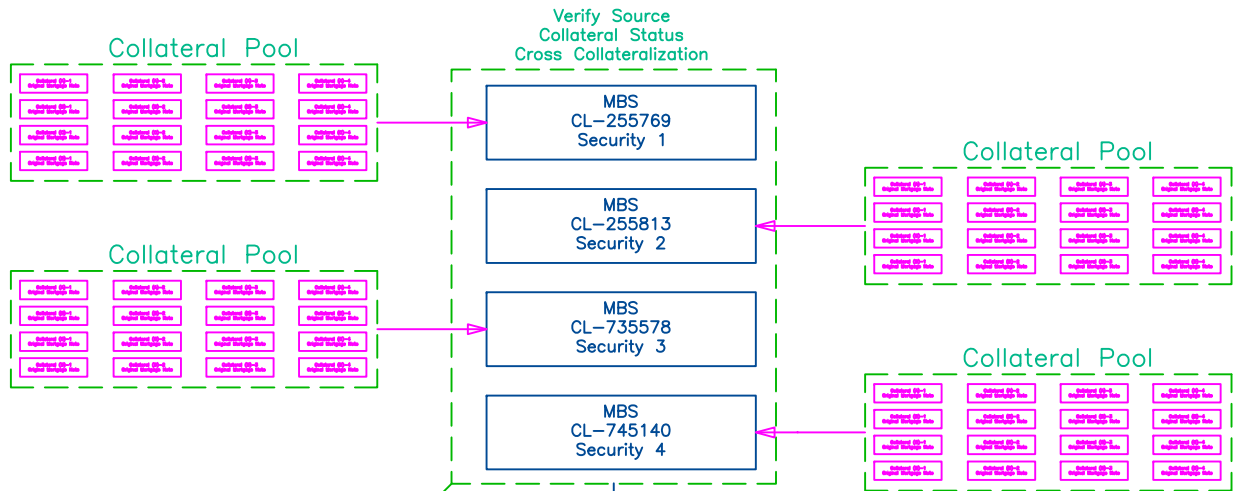

Verify Document Custodian Status
Document Custodian Certificate Holder Cede & Co./DTC

Verify Source Collateral Status Cross Collateralization

Search Procedure Example "A"
Security 7
Security 5
Security 1
Original Collateral

Search Procedure Example "B"
Security 6
Security 5
Security 3
Original Collateral

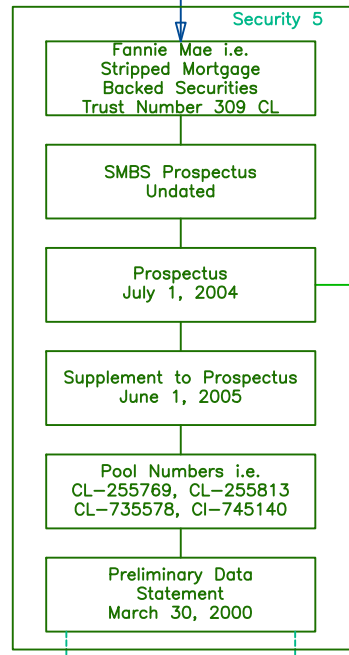

Document Custodian Certificate Holder Cede & Co./DTC
Verify Document Custodian Status

Fannie Mae Mega Trust

Verify Document Custodian Status
Document Custodian Certificate Holder Cede & Co./DTC

Security 6
Trust Number 309 CL Class 1 Pass-Through PO
Defaulted Security Requires Research to Source Collateral

Security 7
Trust Number 309 CL Class 2 Notional IO
Defaulted Security Requires Research to Source Collateral

Document Custodian Certificate Holder Cede & Co./DTC
Verify Document Custodian Status

Collateral Cube

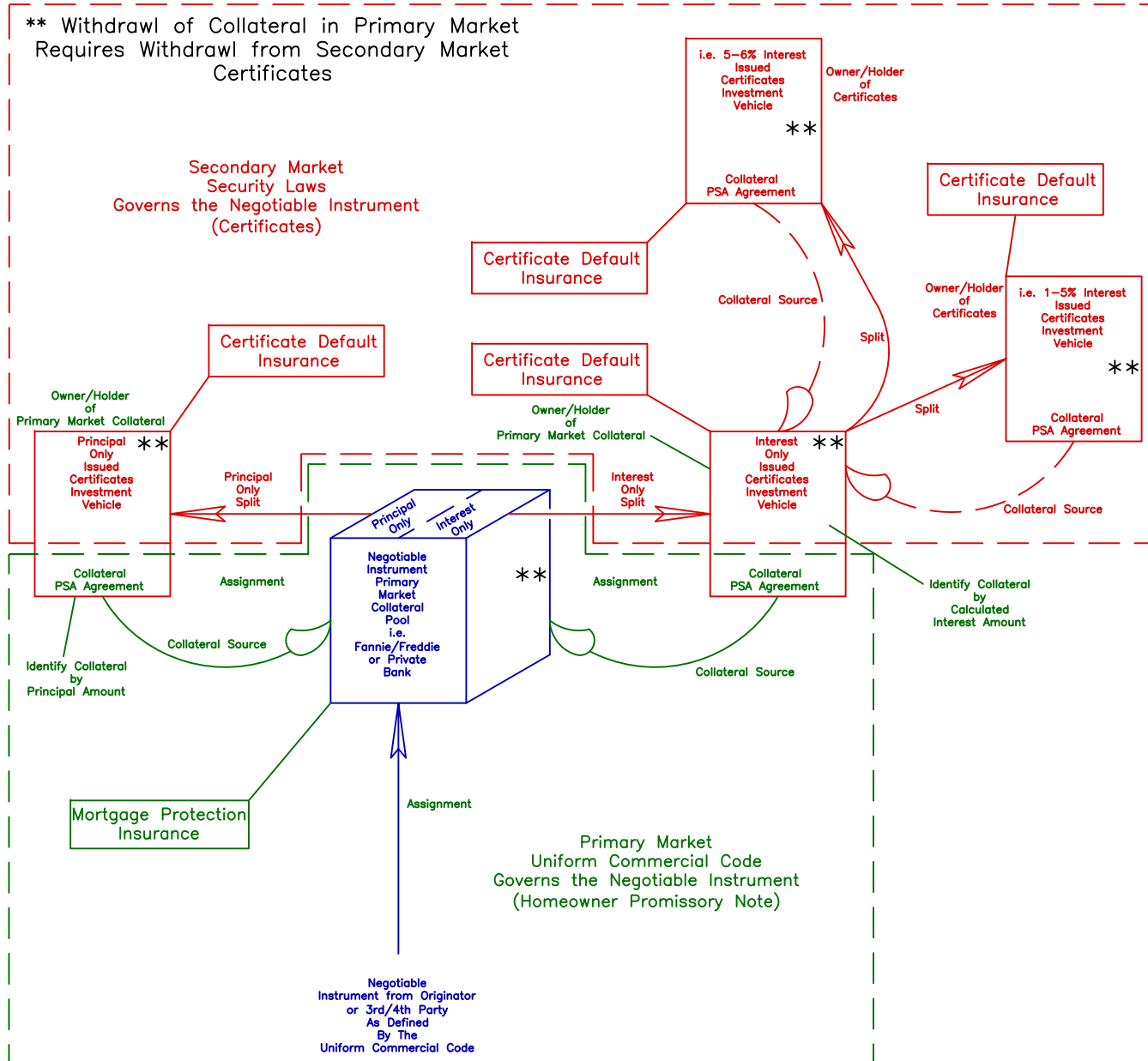

Note: If Mortgage Protection Insurance was filed for in the Primary Market Default there should have been no default in Secondary Market